



Warrington Certification Ltd
Holmesfield Road
Warrington
WA1 2DS
United Kingdom

T : +44 (0) 1925 646 669
W: www.warringtoncertification.com
E: etass@exova.com



Member of
www.eota.eu

**European Technical
Assessment**

**ETA 15/0694
of 12/11/15**

Technical Assessment Body issuing the ETA and designated according to Article 29 of the Regulation (EU) No 305/2011:	
Trade name of the construction product	FISCHER FiPW-E Pipe Wrap
Product family to which the construction product belongs	Fire Stopping and Sealing Product Penetration Seals
Manufacturer	Fischerwerke GmbH & Co.KG Klaus-Fischer-Strasse 1 72178 Waldachtal Germany
Manufacturing plant(s)	E/091
This European Technical Assessment contains	21 pages including 1 Annex(es) which form an integral part of this assessment.
	Annex(es) A - C Contain(s) confidential information and is/are not included in the European Technical Assessment when that assessment is publicly available.
This European Technical Assessment is issued in accordance with regulation (EU) No 305/2011, on the basis of	ETAG 026, edition 2011, used as European Assessment Document (EAD)

General Comments

1. This European Technical Assessment is issued by Warrington Certification Limited on the basis of ETAG 026 Fire Protective Products Part 1: General June 2013, and Part 2: Fire Stopping and Fire Sealing Products Aug 2011, Used as European Assessment Document.
2. This European Technical Assessment is not to be transferred to manufacturers or agents of manufacturers other than those indicated on page 1, or manufacturing plants other than those indicated on page 1.



1 SPECIFIC CONDITIONS OF THE EUROPEAN TECHNICAL ASSESSMENT

1 Technical Description of the Product

(Detailed information and data are given in Annexes)

- 1) FISCHER FiPW-E Pipe Wrap is installed around combustible pipes to form a penetration seal used to reinstate the fire resistance performance of wall and floor constructions, where they have been provided with apertures for the penetration of combustible pipe services.
- 2) FISCHER FiPW-E Pipe Wrap is installed around the pipe at the soffit and upper face of floors and both faces of walls, depending on application and by applying a number of passes to reach the required thickness. Fixing specifications and number of passes are detailed in Annex A.
- 3) FISCHER FiPW-E Pipe Wrap can be used with FISCHER FiAM Intumescent Acoustic Mastic to seal the space between the combustible pipe and the aperture to close gap sizes as specified in Annex A.
- 4) The applicant has submitted a written declaration that the product and/or constituents of the product contains no substances which have been classified as dangerous according to Directive 67/548/EEC and Regulation (EC) No. 1272/2008 and listed in the 'indicative list on dangerous substances' of the EGDS – taking into account the installation conditions of the construction product and the release scenarios resulting from there.

In addition to the specific clauses relating to dangerous substances contained in this European Technical Assessment, there may be other requirements applicable to the products falling within its scope (e.g. transposed European legislation and national laws, regulations and administrative provisions). In order to meet the provisions of the Construction Products Regulation, these requirements need also to be complied with, when and where they apply.

The use category of FISCHER FiPW-E Pipe Wrap in relation to BWR 3 (Hygiene, health and environment) is IA1, S/W3.

- 5) External use- ETAG 026-2 (used as European Assessment Document EAD) Type X.



2 Specification Of The Intended Use In Accordance With The Relevant EAD

2.1 Intended Use

- 1) The intended use of FISCHER FiPW-E Pipe Wrap is to reinstate the fire resistance performance of wall and floor constructions, where they are penetrated by various combustible pipe services.

The specific elements of construction that the system FISCHER FiPW-E Pipe Wrap may be used is as follows:

- | | |
|-----------------|---|
| Flexible walls: | The wall must have a minimum thickness of 100 mm and comprise timber or steel studs line on both faces with minimum 2 layers of 12.5 mm thick, 'Type F' Gypsum boards according to EN 520. In timber stud walls, no part of the penetration seal shall be closer than 100mm to a stud, and minimum 100 mm of insulation of class A1 or A2 according to EN 13501-1, is provided within the cavity between the penetration seal and the stud. |
| Rigid walls: | The wall must have a minimum thickness of 100 mm and comprise of concrete, aerated concrete or masonry, with a minimum density of 650 km/m^3 . |
| Rigid floor: | The floor must have a minimum thickness of 150 mm and comprise of concrete, aerated concrete or masonry, with a minimum density of 650 km/m^3 . |

- 2) The supporting construction must be classified in accordance with EN 13501-2 for the required fire resistance period.
- 3) The system FISCHER FiPW-E Pipe Wrap may be used to provide a penetration seal with specific combustible pipes, single only (for details see Annex A).
- 4) Apertures in the separating element shall be maximum oversize with respect to the pipe diameter according to the tables listed in Annex A. The remaining annular space/gap shall be infilled with FISCHER FiAM Intumescent Mastic. Apertures for the penetration of pipes shall be separated by a minimum of 200 mm.
- 5) The provisions made in this European Technical Assessment are based on an assumed working life of the system FISCHER FiPW-E Pipe Wrap of 10 years, The indications given on the working life cannot be interpreted as a guarantee given by the producer, but are to be regarded only as a means for choosing the right products in relation to the expected economically reasonable working life of the works.
- 6) Services in walls shall be supported at maximum 400mm from the face of the separating element for walls, and 400mm above the surface of the floor.

2.2 Use Category

Type X: Intended for use in conditions exposed to weathering.



Performance Of The Product And References To The Methods Used For Its Assessment

Product Type: Wrap		Intended use: Pipe Closure Device
Basic requirement for construction work	Basic Requirement	Performance
BWR 1 Mechanical resistance and stability		
	None	Not relevant
BWR 2 Safety in case of fire		
EN 13501-1	Reaction to fire	Class E
EN 13501-2	Resistance to fire	Annex A
BWR 3 Hygiene, Health and the Environment		
EN 1026:2000	Air permeability	No performance determined
ETAG 026-3 Annex C	Water permeability	No performance determined
Declaration by manufacturer	Release of dangerous substances	Use category IA1, S/W3 Declaration of manufacturer
BWR 4 Safety in use		
EOTA TR 001:2003	Mechanical resistance and stability	No performance determined
EOTA TR 001:2003	Resistance to impact/movement	No performance determined
EOTA TR 001:2003	Adhesion	No performance determined
BWR 5 Protection against noise		
EN 10140-2/ EN ISO 717-1	Airborne sound insulation	No performance determined
BWR 6 Energy, Economy and Heat Retention		
EN 12664, EN 12667 or EN 12939	Thermal properties	No performance determined
EN ISO 12572 EN12086	Water vapour permeability	No performance determined
General aspects relating to fitness for use		
EOTA TR 024:2009	Durability and serviceability	X
BWR 7 Sustainable use of natural resources		
		No performance determined



3 Assessment And Verification Of Constancy Of Performance (Hereinafter AVCP) System Applied, With References To Its Legal base

According to the decision 1999/454/EC of the European Commission the system of assessment and verification of constancy of performance (see Annex V to the Regulation (EU) No 305/2011) given in the following table apply:

Products	Intended uses	Level or Class	System
Fire stopping and fire sealing products	For fire compartmentation and / or fire protection or fire performance	Any	System 1

4 Technical Details Necessary For The Implementation Of The AVCP System, As Provided For In The Applicable EAD.

Tasks for the Manufacturer

Factory production control

The manufacturer shall exercise permanent internal control of production. All the elements, requirements and provisions adopted by the manufacturer shall be documented in a systematic manner in the form of written policies and procedures, including records of results performed. This production control system shall ensure that the product is in conformity with this European technical assessment.

The manufacturer may only use constituent materials stated in the technical documentation of this European technical assessment.

The factory production control shall be in accordance with the Control Plan of 03.06.15 relating to the European Technical Assessment ETA– 15/0694 "Control Plan" is laid down in the context of the factory production control system operated by the manufacturer and deposited at Warrington Certification Limited.

The results of factory production control shall be recorded and evaluated in accordance with the provisions of the Control Plan.

Other tasks of manufacturer

Additional information

The manufacturer shall provide a technical data sheet and an installation instruction with the following minimum information:

(a) Technical data sheet:

- Field of application:
- Building elements for which the penetration seal is suitable, type and properties of the building elements like minimum thickness, density, and - in case of lightweight constructions – the construction requirements.



- Services for which the penetration seal is suitable, type and properties of the services like material, diameter, thickness etc. in case of pipes including insulation materials; necessary/allowed supports/fixings (e.g. cable trays)
- Limits in size, minimum thickness etc. of the penetration seal

Construction of the penetration seal including the necessary components and additional products (e.g. backfilling material) with clear indication whether they are generic or specific (b)
Installation instruction:

- Steps to be followed
- Procedure in case of retrofitting.

The manufacturer shall make a declaration of conformity, stating that the construction product is in conformity with the provisions of the European technical assessment ETA 15/0694.

Tasks of approved bodies

The approved body shall perform the

- initial type-testing of the product,
- initial inspection of factory and of factory production control,
- continuous surveillance, assessment and approval of factory production control,

In accordance with the provisions laid down in the "Control Plan" of 03.06.15 relating to the European Technical Assessment 15/0694.

The approved body shall retain the essential points of its actions referred to above and state the results obtained and conclusions drawn in a written report.

The approved certification body involved by the manufacturer shall issue an EC certificate of conformity of the product stating the conformity with the provisions of this European technical assessment.

In cases where the provisions of the European technical assessment and its "Control Plan" are no longer fulfilled the certification body shall withdraw the certificate of conformity and inform the Warrington Certification Limited without delay.



Signatories

Responsible Officer N. Stoyanov* - Certification Engineer

Approved C. Abbott* - Principal Certification Engineer

* For and on behalf of Warrington Certification Limited.



Annex A

Resistance to Fire Classification of FISCHER FiPW-E Pipe Wrap

A.1 Intumescent Thickness

The permitted thickness of the intumescent material various ranges of pipe diameters.

Intumescent Thickness	
Pipe Diameter	Intumescent Material
ø 32 mm - ø 50 mm	1 off 40 mm (W) x 2 (T)
ø 51 mm - ø 82 mm	2 off 40 mm (W) x 2 (T)
ø 83 mm - ø 115 mm	3 off 40 mm (W) x 2 (T)
ø 116 mm - ø 160 mm	4 off 40 mm (W) x 2 (T)
ø 161 mm - ø 200 mm	5 off 40 mm (W) x 2 (T)
ø 201 mm - ø 250 mm	6 off 40 mm (W) x 2 (T)

A.2 Floor construction with thickness of minimum 150 mm

A.2.1 Penetration seal with FISCHER FiPW-E Pipe Wrap installed within both sides of rigid floor

Construction details: Combustible pipes installed with a single FISCHER FiPW-E Pipe Wrap within both sides. Maximum annular space according to the tables listed in A.2.1.1 to A.2.1.3 filled with FISCHER FiAM Intumescent Acoustic Mastic.

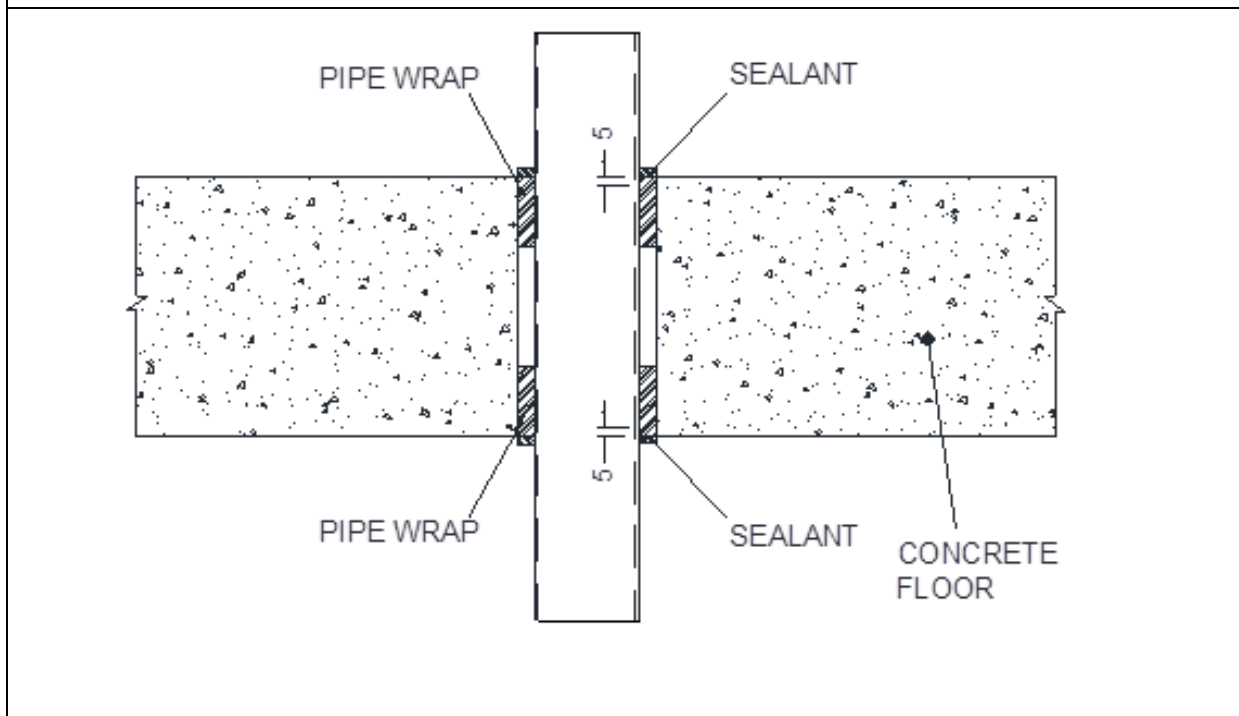

A.2.1.1 PVC-U pipes with FISCHER FiPW-E Pipe Wrap installed within both sides of rigid floor

PVC pipes according to EN 1452 with FISCHER FiPW-E Pipe Wrap.

FISCHER FiPW-E Pipe Wrap Friction Fitted Flush to Both Sides of Rigid Floor (min 150 mm thick) PVC Pipes			
Penetration Specification	Wrap Size / Number	Annulus Space (mm)	Classification
PVC Pipe 32 mm ϕ 1.8 mm wall thickness	1 off 40 mm (W) x 2 mm (T)	4	EI 120 U/C
PVC Pipe 40 mm ϕ 1.8 mm wall thickness			
PVC Pipe 50 mm ϕ 1.8 mm wall thickness			
PVC Pipe 200 mm ϕ 7.7 mm wall thickness	5 off 40 mm (W) x 2 mm (T)	12	E 120 U/C EI 90 U/C
PVC Pipe 200 mm ϕ 9.6 mm wall thickness			EI 60 U/C

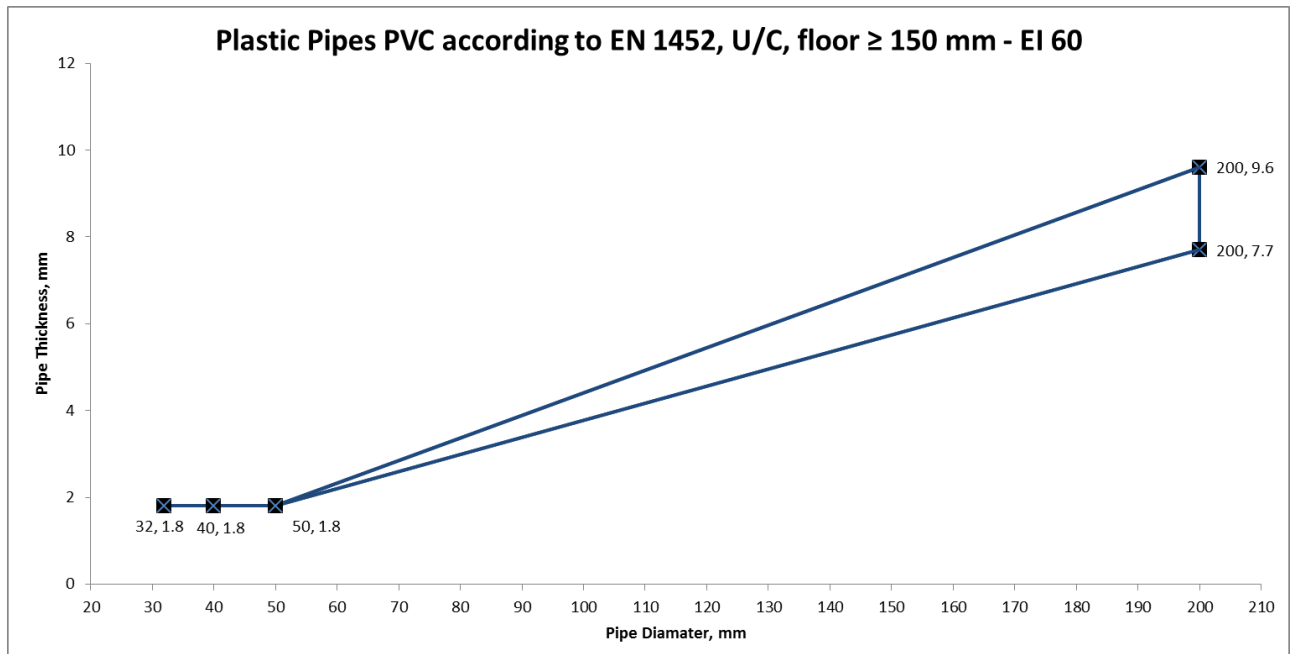

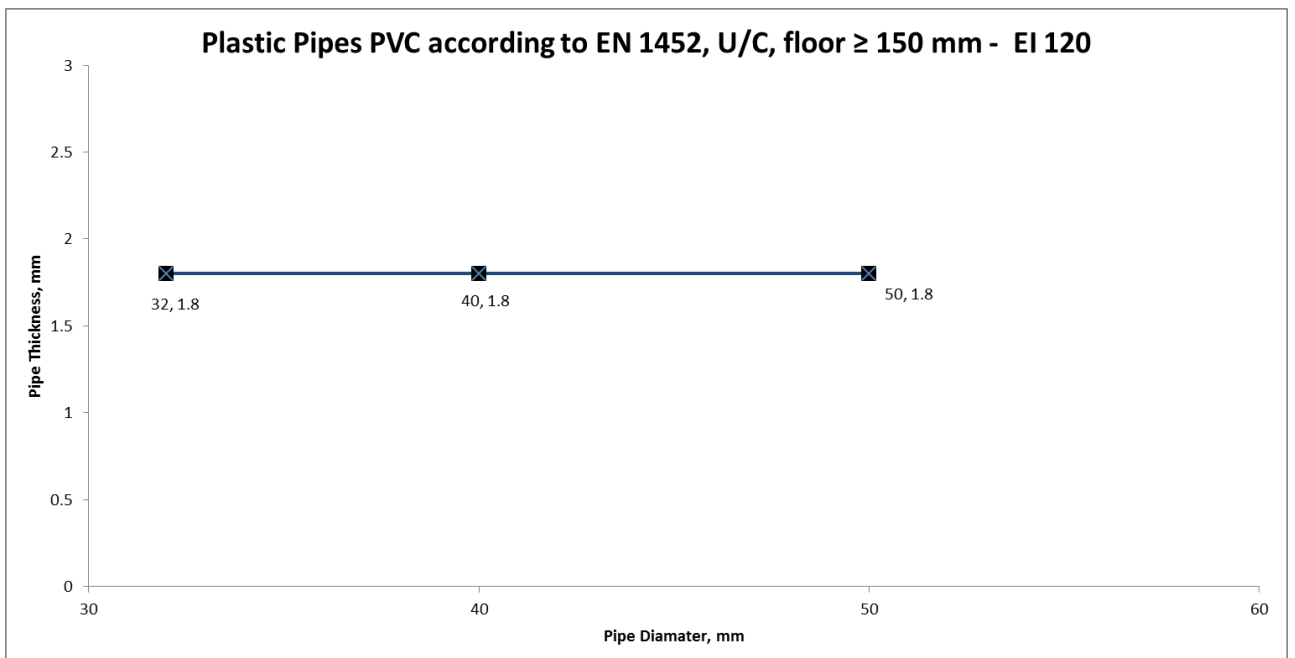
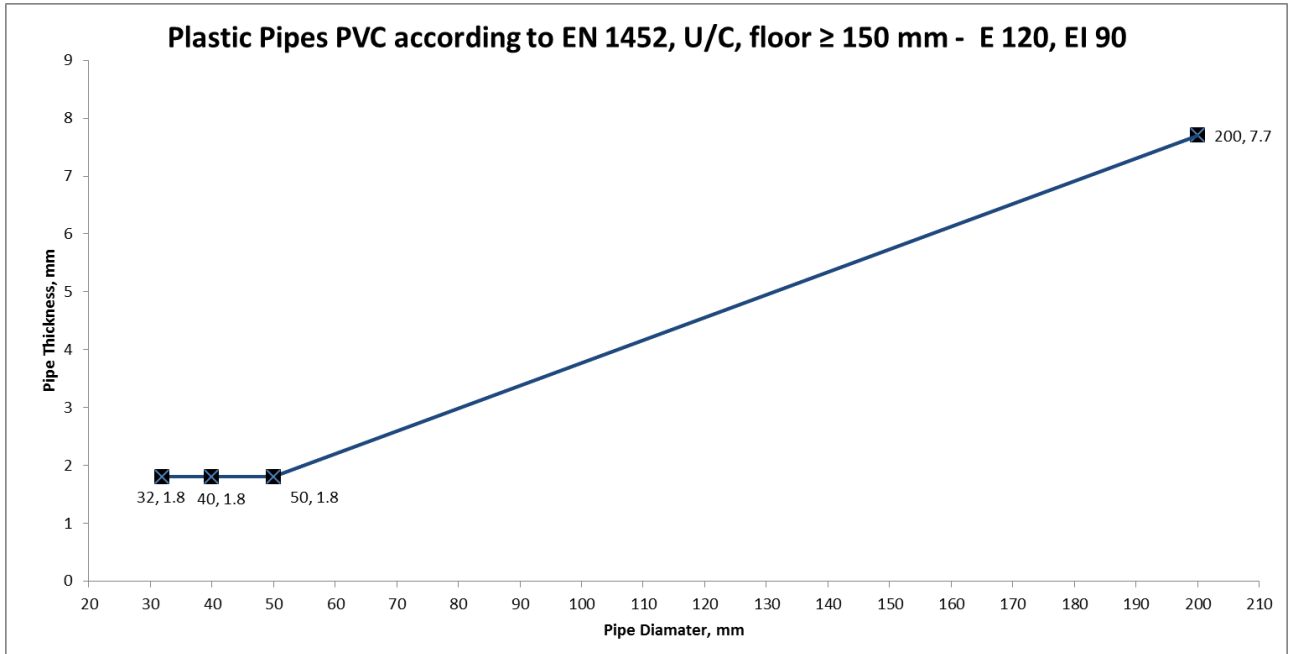

A.2.1.2 PP pipes with FISCHER FiPW-E Pipe Wrap installed within both sides of rigid floor

PP pipes according to EN 1451 with FISCHER FiPW-E Pipe Wrap.

FISCHER FiPW-E Pipe Wrap, Friction Fitted Flush to Both Sides of Rigid Floor (min 150 mm thick) PP Pipes			
Penetration Specification	Wrap Size / Number	Annulus Space (mm)	Classification
PP Pipe 32 mm ϕ 2.9 mm wall thickness	1 off 40 mm (W) x 2 mm (T)	4	EI 120 U/C
PP Pipe 40 mm ϕ 2.9 mm wall thickness			
PP Pipe 50 mm ϕ 2.9 mm wall thickness			
PP Pipe 200 mm ϕ 4.9 mm wall thickness	5 off 40 mm (W) x 2 mm (T)	12	E 20 U/C EI 15 U/C
PP Pipe 200 mm ϕ 18.2 mm wall thickness			E 120 U/C EI 90 U/C

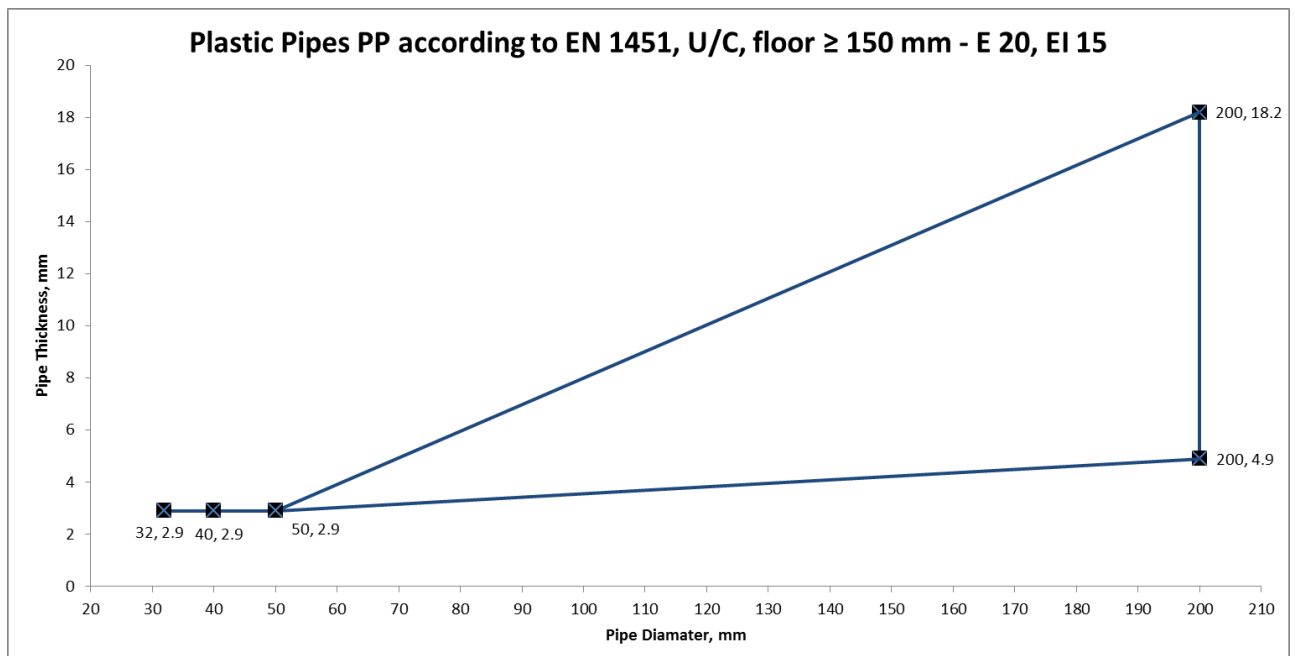

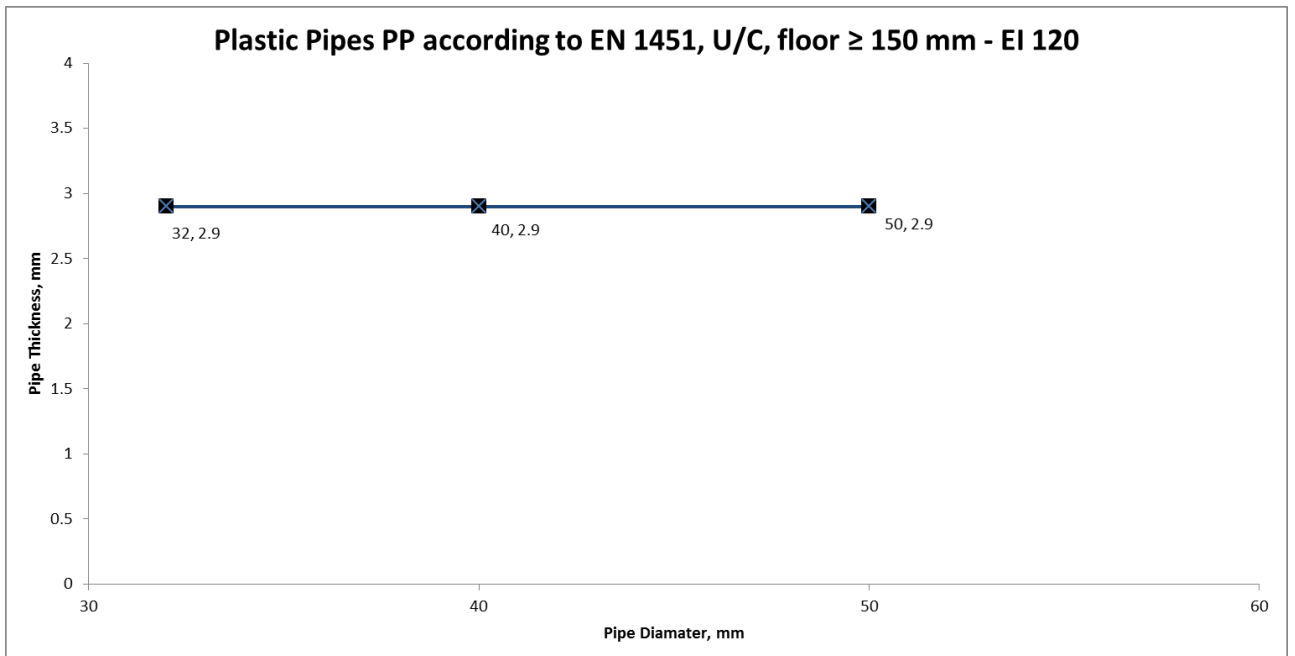
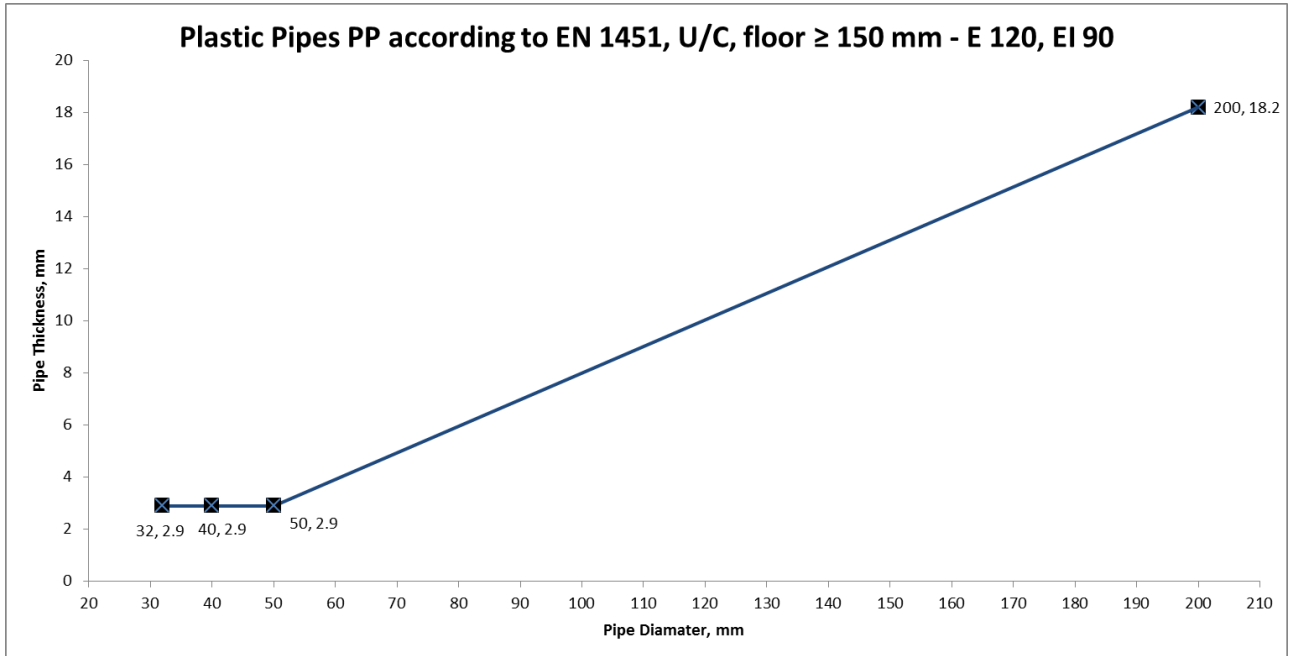

A.2.1.3 HDPE pipes with FISCHER FiPW-E Pipe Wrap installed within both sides of rigid floor

HDPE pipes according to EN 1519 with FISCHER FiPW-E Pipe Wrap.

FISCHER FiPW-E Pipe Wrap Friction Fitted Flush to Both Sides of Rigid Floor (min 150 mm thick) HDPE Pipes			
Penetration Specification	Wrap Size / Number	Annulus Space (mm)	Classification
HDPE Pipe 32 mm ϕ 2.9 mm wall thickness	1 off 40 mm (W) x 2 mm (T)	4	EI 120 U/C
HDPE Pipe 40 mm ϕ 2.9 mm wall thickness			
HDPE Pipe 50 mm ϕ 2.9 mm wall thickness			
HDPE Pipe 200 mm ϕ 4.9 mm wall thickness	5 off 40 mm (W) x 2 mm (T)	12	
HDPE Pipe 200 mm ϕ 11.4 mm wall thickness			

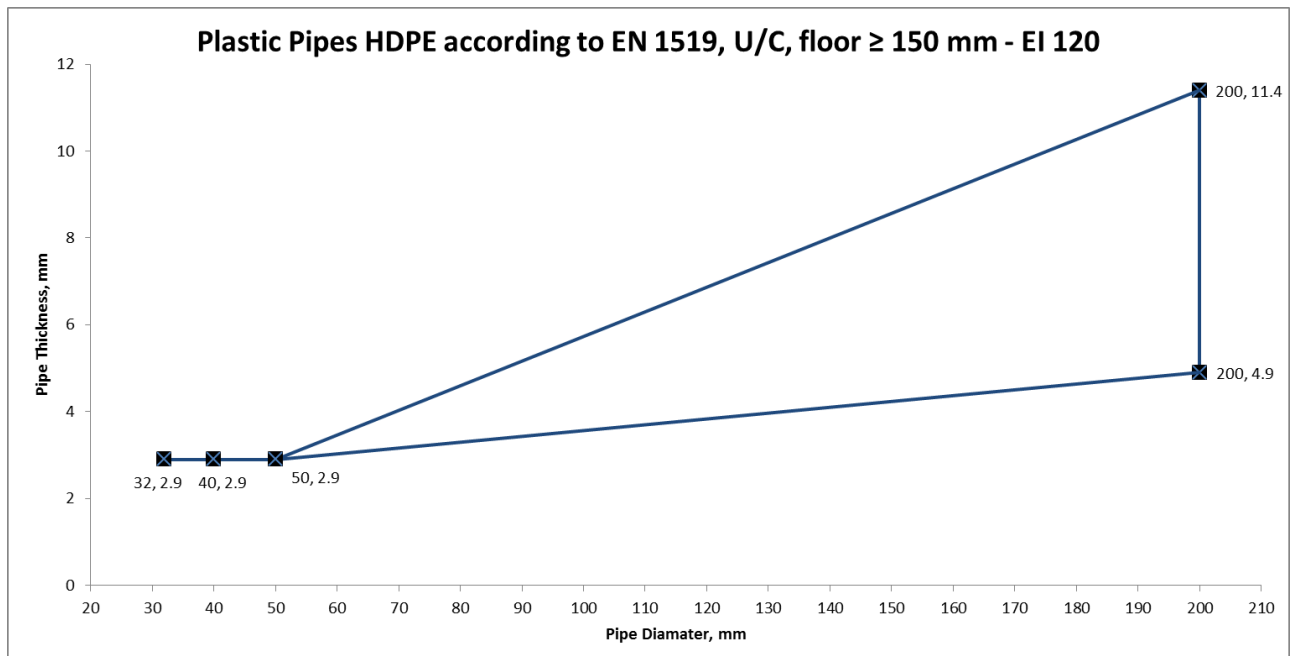

A.3 Wall construction with thickness of minimum 100 mm

A.3.1 Penetration seal with FISCHER FiPW-E Pipe Wrap installed within both sides of flexible or rigid wall

Construction details: Combustible pipes installed with a single FISCHER FiPW-E Pipe Wrap within both sides. Maximum annular space according to the tables listed in A.3.1.1 to A.3.1.3 filled with FISCHER FiAM Intumescent Acoustic Mastic.

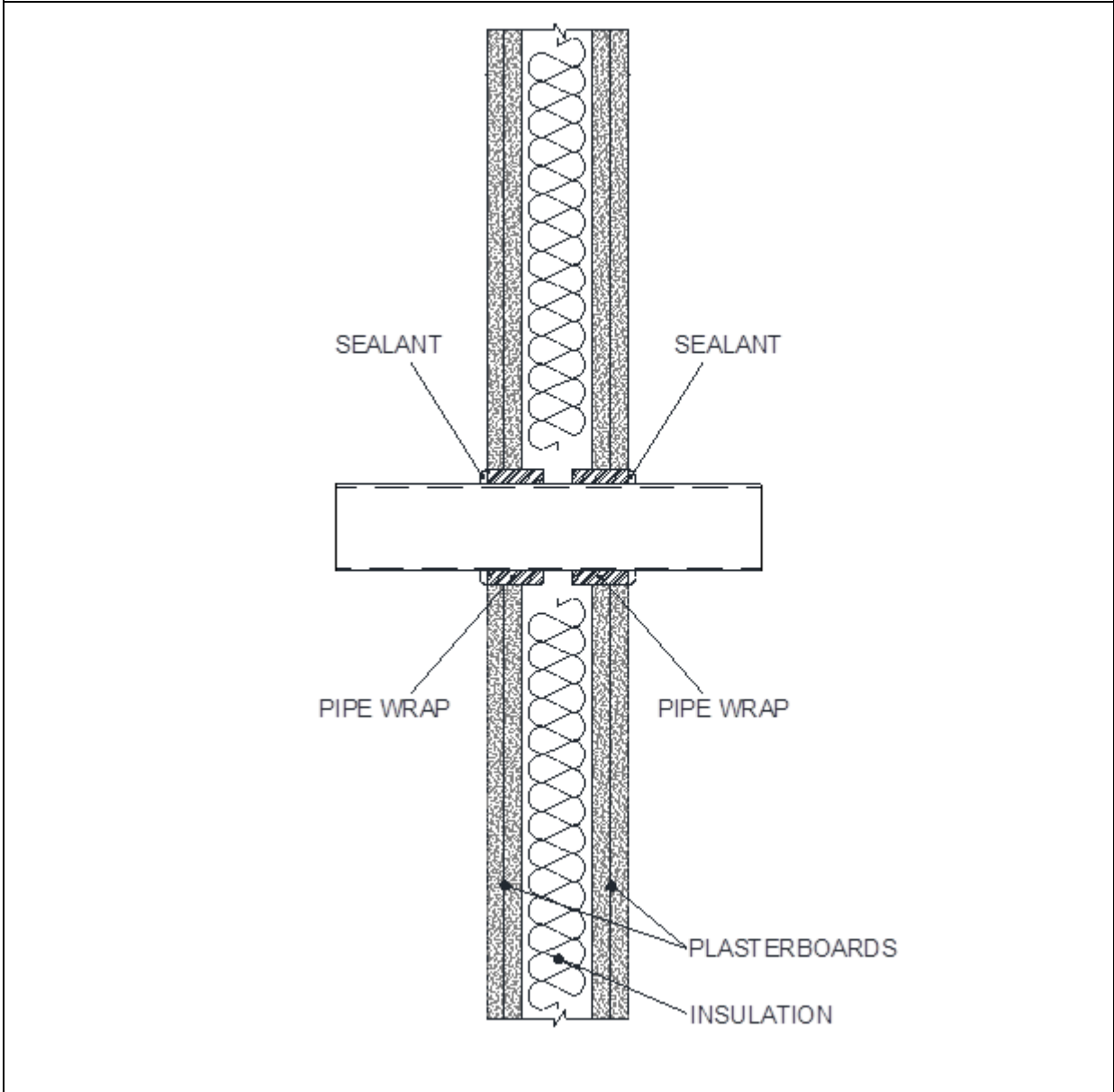

A.3.1.1 PVC pipes with FISCHER FiPW-E Pipe Wrap installed within both sides of flexible or rigid wall

PVC pipes according to EN 1452 with FISCHER FiPW-E Pipe Wrap.

FISCHER FiPW-E Pipe Wrap, Friction Fitted Flush to Both Sides of Flexible or Rigid Wall (min 100 mm thick) PVC Pipes			
Penetration Specification	Wrap Size / Number	Annulus Space (mm)	Classification
PVC Pipe 32 mm ϕ 1.8 mm wall thickness	1 off 40 mm (W) x 2 mm (T)	4	EI 120 U/C
PVC Pipe 40 mm ϕ 1.8 mm wall thickness			
PVC Pipe 50 mm ϕ 1.8 mm wall thickness			
PVC Pipe 160 mm ϕ 6.2 mm wall thickness	4 off 40 mm (W) x 2 mm (T)	10	EI 90 U/C
PVC Pipe 160 mm ϕ 9.5 mm wall thickness			
PVC Pipe 200 mm ϕ 7.7 mm wall thickness	5 off 40 mm (W) x 2 mm (T)	12	EI 120 U/C
PVC Pipe 200 mm ϕ 9.6 mm wall thickness			

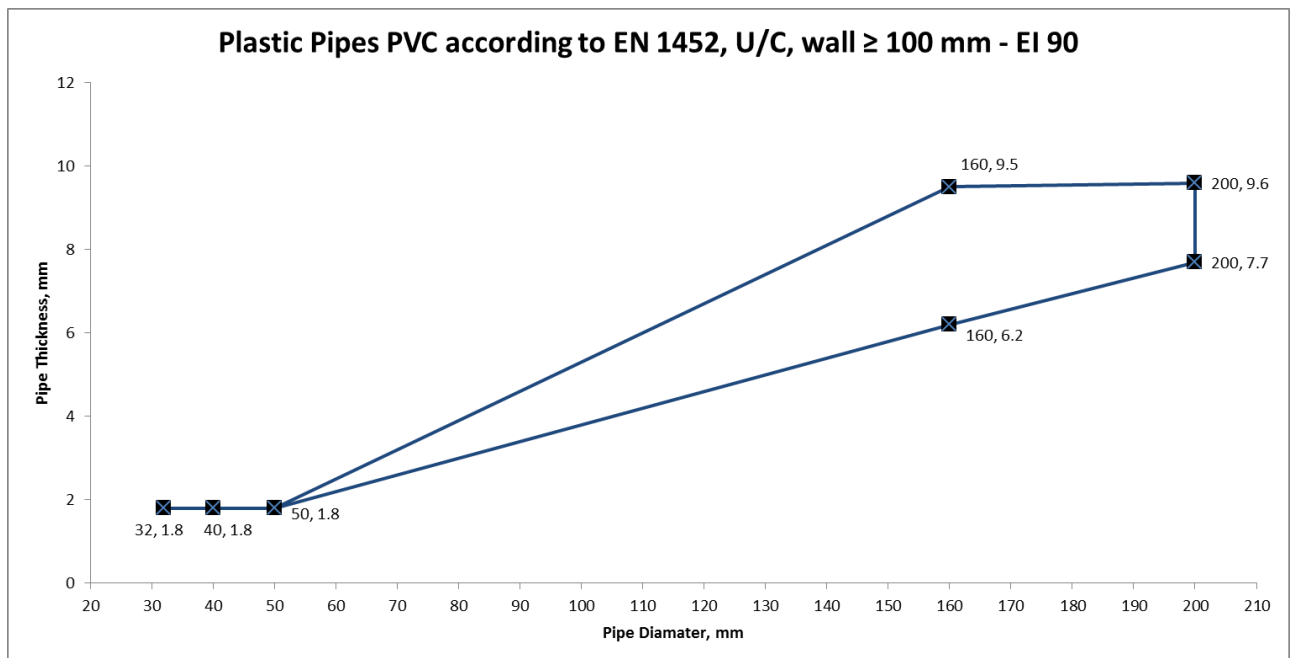

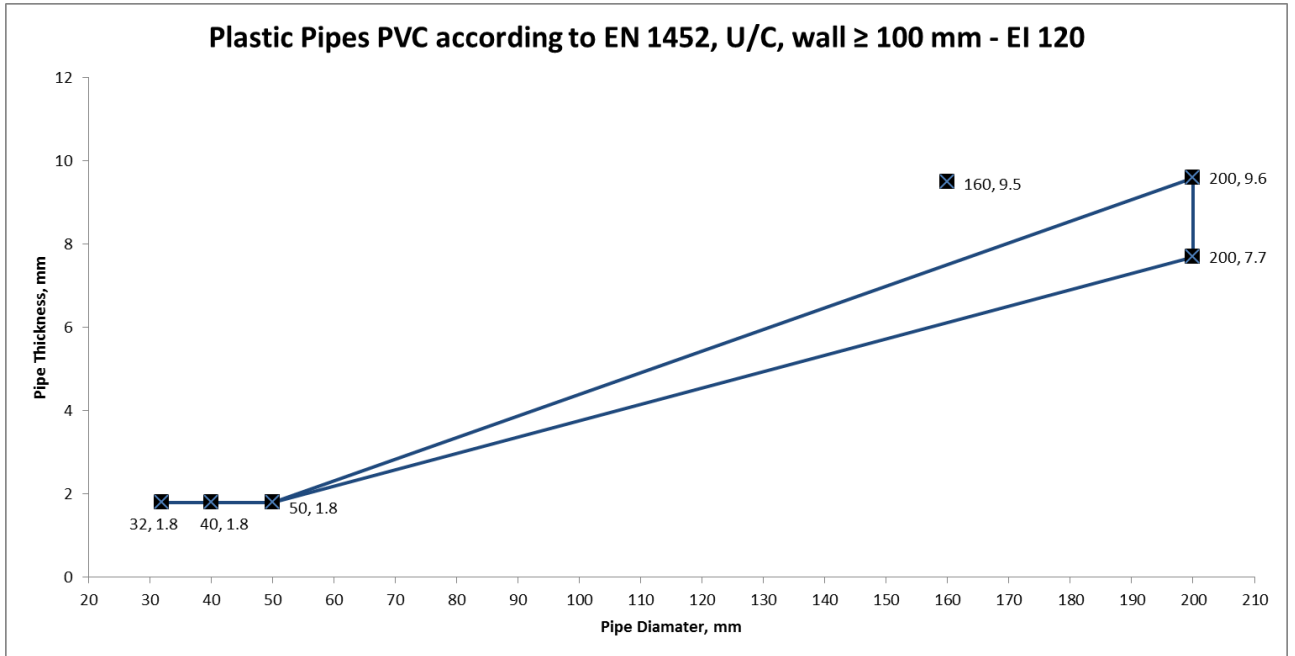

A.3.1.2 PP pipes FISCHER FiPW-E Pipe Wrap installed within both sides of flexible or rigid wall

PP pipes according to EN 1451 with FISCHER FiPW-E Pipe Wrap.

FISCHER FiPW-E Pipe Wrap Friction Fitted Flush to Both Sides of Flexible or Rigid Wall (min 100 mm thick) PP Pipes			
Penetration Specification	Wrap Size / Number	Annulus Space (mm)	Classification
PP Pipe 32 mm ϕ 2.9 mm wall thickness	1 off 40 mm (W) x 2 mm (T)	4	EI 120 U/C
PP Pipe 40 mm ϕ 2.9 mm wall thickness			
PP Pipe 50 mm ϕ 2.9 mm wall thickness			
PP Pipe 160 mm ϕ 4.0 mm wall thickness	4 off 40 mm (W) x 2 mm (T)	10	E 120 U/C EI 90 U/C
PP Pipe 160 mm ϕ 14.6 mm wall thickness			EI 120 U/C
PP Pipe 200 mm ϕ 4.9 mm wall thickness	5 off 40 mm (W) x 2 mm (T)	12	E 120 U/C EI 90 U/C
PP Pipe 200 mm ϕ 18.2 mm wall thickness			EI 120 U/C
PP Pipe 250 mm ϕ 10.1 mm wall thickness	6 off 40 mm (W) x 2 mm (T)	14	E 120 U/C EI 20 U/C

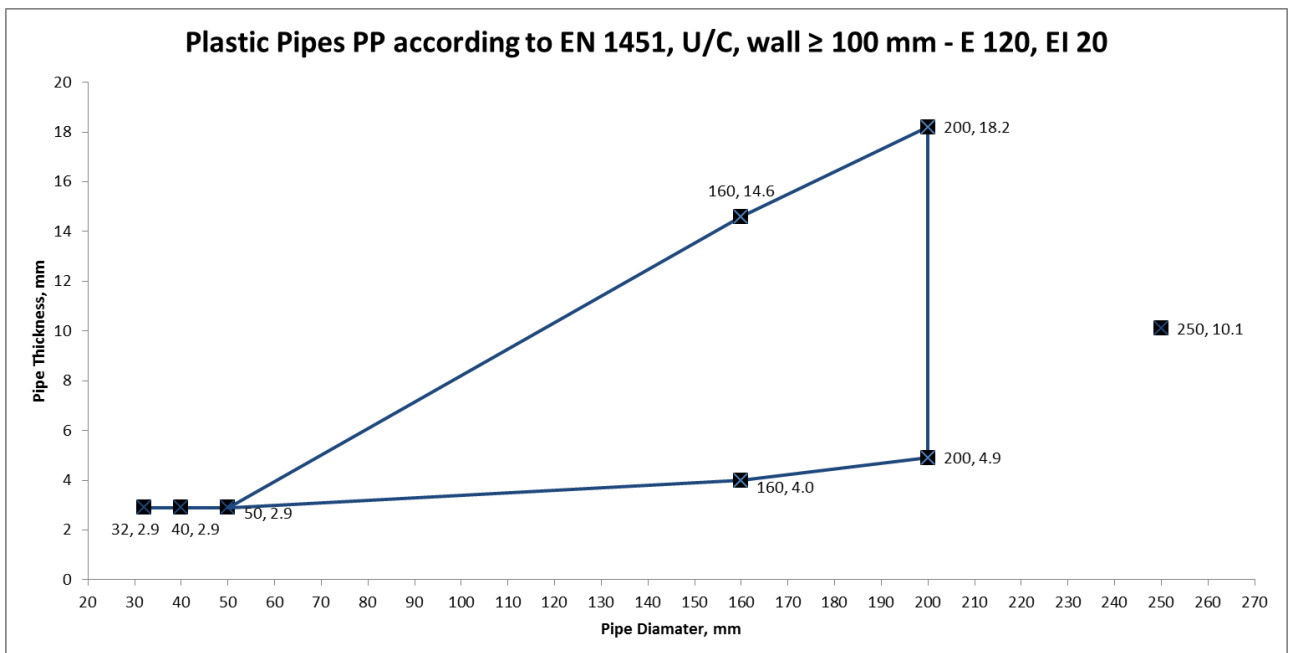

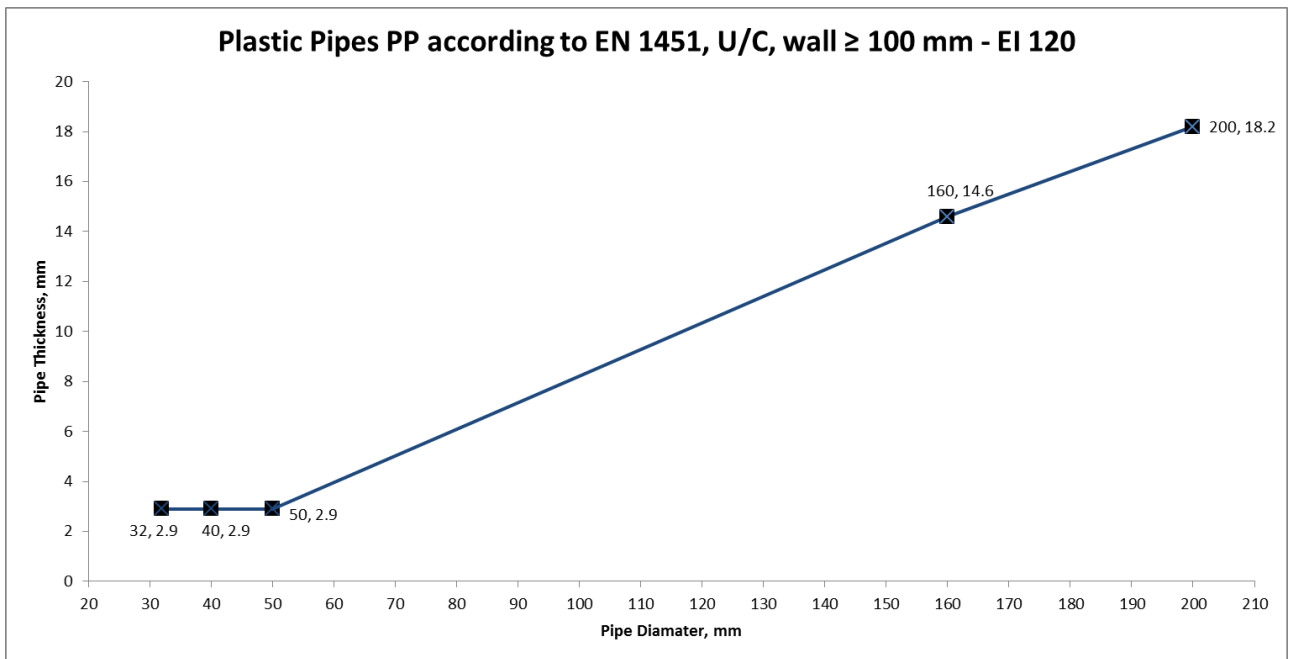
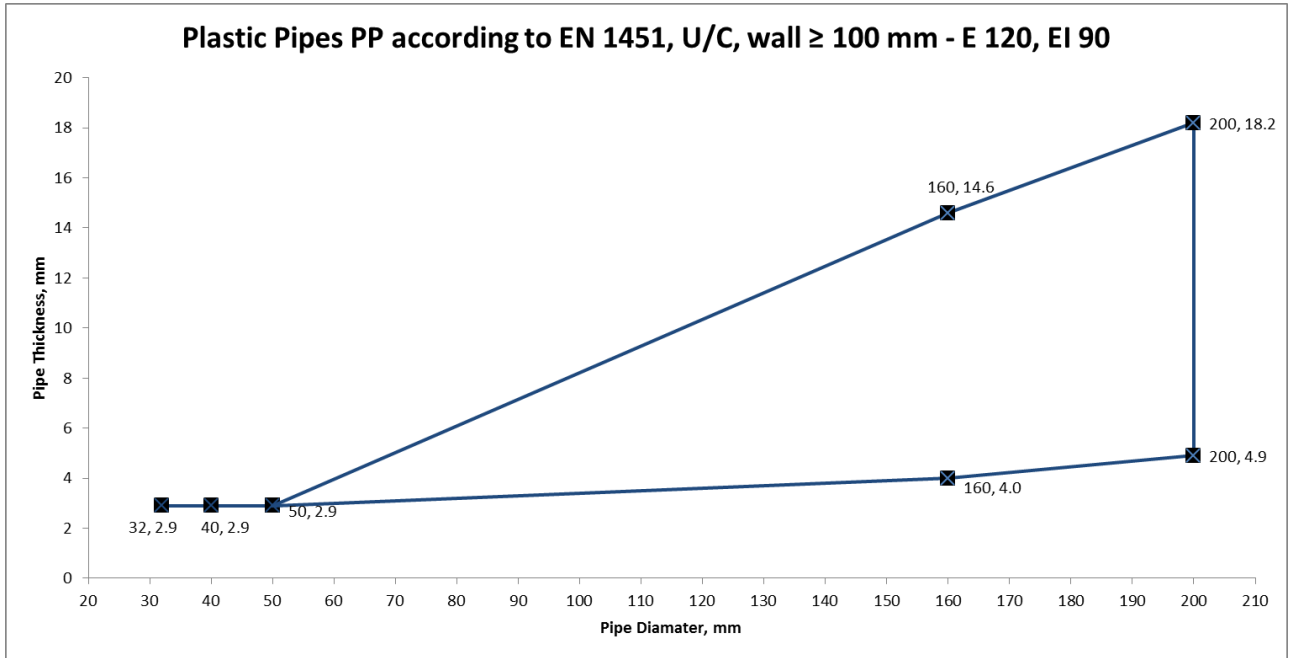

A.3.1.3 PE pipes with FISCHER FiPW-E Pipe Wrap installed within both sides of flexible or rigid wall

PE pipes according to EN ISO 15494 with FISCHER FiPW-E Pipe Wrap.

FISCHER FiPW-E Pipe Wrap Friction Fitted Flush to Both Sides of Flexible or Rigid Wall (min 100 mm thick) PE Pipes			
Penetration Specification	Wrap Size / Number	Annulus Space (mm)	Classification
PE Pipe 32 mm ϕ 2.9 mm wall thickness	1 off 40 mm (W) x 2 mm (T)	4	EI 120 U/C
PE Pipe 40 mm ϕ 2.9 mm wall thickness			
PE Pipe 50 mm ϕ 2.9 mm wall thickness			
PE Pipe 160 mm ϕ 4.9 mm wall thickness	4 off 40 mm (W) x 2 mm (T)	10	EI 15 U/C
PE Pipe 160 mm ϕ 9.5 mm wall thickness			EI 90 U/C
PE Pipe 200 mm ϕ 4.9 mm wall thickness	5 off 40 mm (W) x 2 mm (T)	12	EI 15 U/C
PE Pipe 200 mm ϕ 18.4 mm wall thickness			EI 120 U/C

